

FRYER

MACHINE SYSTEMS

Precision Built Solutions



Fryer / Siemens Touch 2300

Advanced CNC Control for Milling and Turning

Conversational CNC Power at Your Fingertips

The Fryer / Siemens Touch 2300 CNC provides world class technology and ultra-advanced features in an intuitive user interface. Based on the powerful Siemens 840D SL, this state of the art platform provides the ultimate for 5 axis, high speed machining, horizontal machine and turning applications alike. Fast set-up cycles, one button hot keys and built in probe cycles speed the set-up process. Shop floor programming, G code programming, large program storage and Ethernet connectivity speed the programming process. 3D solid model graphic verification, handwheel run and easy interrupt speed the first article process.



Ease of Use

- Smart operation with Multi-Touch 19" screen
- One touch keys control many functions
- Shop floor conversational programming
- Manual Mode with Do-One cycles
- Animated cycles with graphics and help
- Handwheel run
- One button tool changes
- Advanced Intuitive tool and part probing cycles
- 3D Shopfloor simulation with cycle time display
- Selectable level lockout key

Powerful Features

- Advanced 5-Axis Operation
- Mid-program restart
- Multiple Clamping
- High speed machining
- Collision avoidance
- Adaptive feed
- 5 axis plus capability
- Mixed Technology – Milling, turning, grinding...
- Compatible with tool presetters to import tool data automatically
- In-process measuring
- DXF Import
- Mindsphere
- Connected shop floor

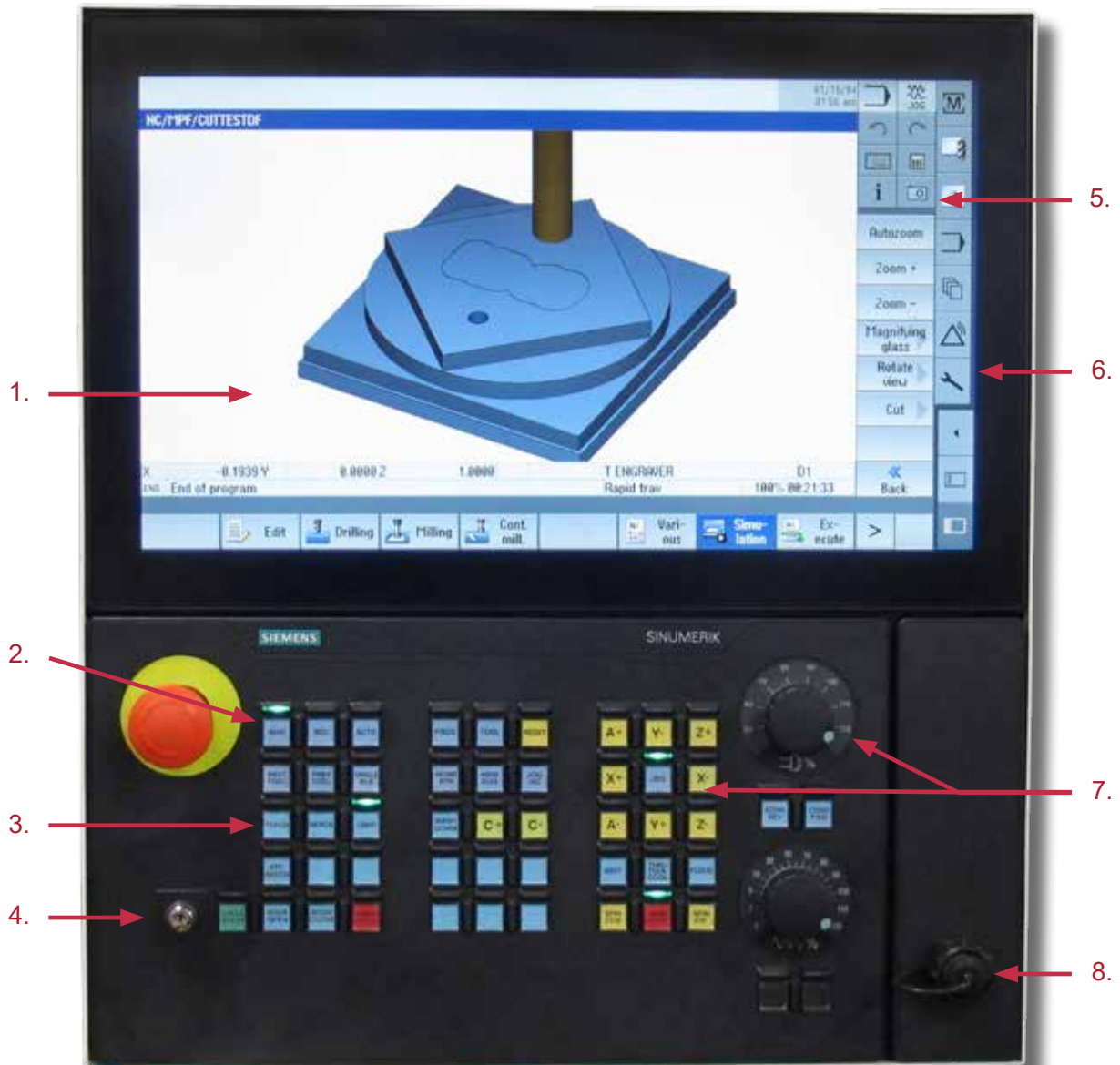

1. Multi-Touch Smart Screen

19" touch screen features a high-resolution, digital color monitor. Finger motions control pinch, zoom and scroll.

2. Mode Select

Provides easy navigation for set up, programming and operation.

3. Set-up Hot Keys

Buttons such as Next Tool/Previous Tool simplify set-up and operation of the machine.

4. Edit Lockout Key

Edit Lockout Keys allow controlled access of editing programs and machine operations.

5. Soft Keys

Each screen has individualized touch activated function keys. Alpha-numeric keyboards and directional keypads also pop up when needed

6. Side Screen

Pop out screen allows you to custom configure what is displayed like cameras, web server, machine run times, etc.

7. Function Keys

Feed rate and spindle speed override dials, axis jog keys and keys for spindle direction and coolant.

8. USB Port

High-speed USB port for file transfer via standard flash drive.

Conversational Programming

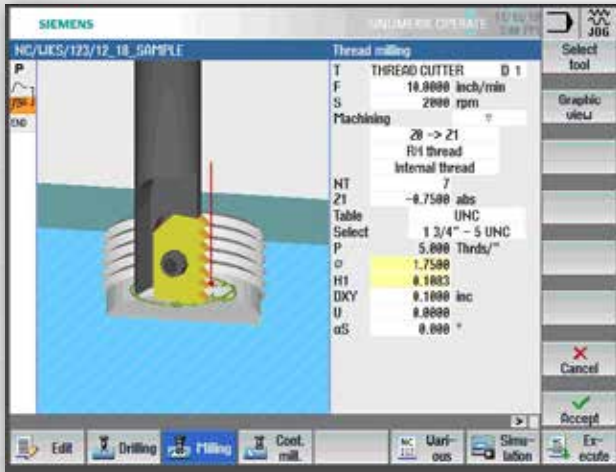

THREAD MILLING

What is usually a complicated programming operation becomes a simple fill in one box procedure. External/internal threads, inch/metric, right hand/left hand threads are all there in this cycle.

POCKETING

You choose your tool, speeds and feeds, pocket size, depth and how you want your tool to enter the material. The cycle does the rest. If you just need to make one quick pocket, why write a program? In Manual Mode all machining cycles are available to run by themselves as Do-One operations with no program required.

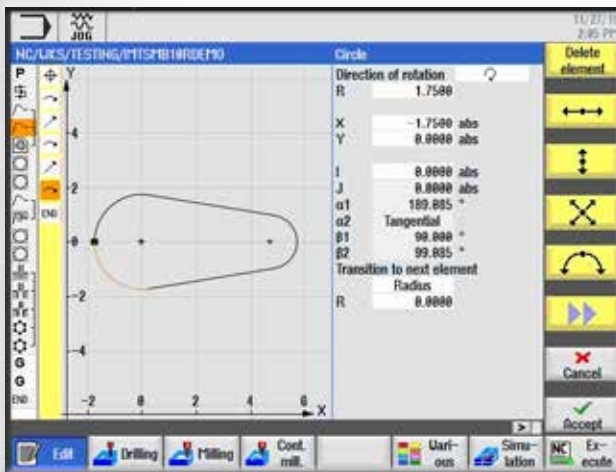
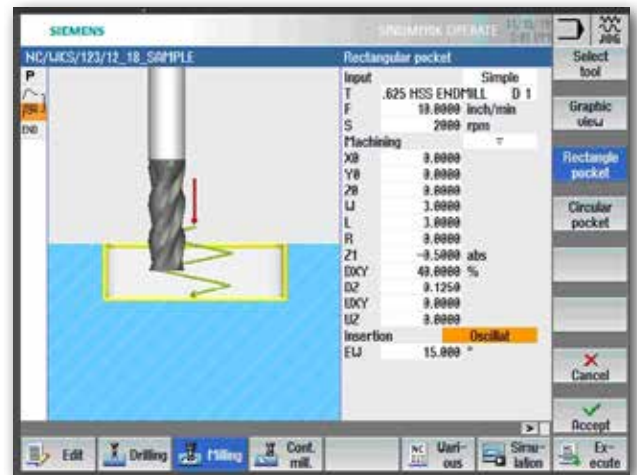

CONTOUR EDITOR

The Contour Editor lets you create simple or complex tool paths. As you enter dimensions the path is visually generated. Don't know an end point? The editor will fill-in missing points.

G Code Programming

G CODE PROGRAMMING

The Fryer / Siemens Touch 2300 CNC also offers standard part programming in either Siemens G Code or emulated ISO/Fanuc mode. Different colors for Feed and Rapid moves and M code commands allow you to search through the program faster. Programs posted from CAD-CAM systems can also be simulated before running. Full editing, renumbering as well as find and replace are included.

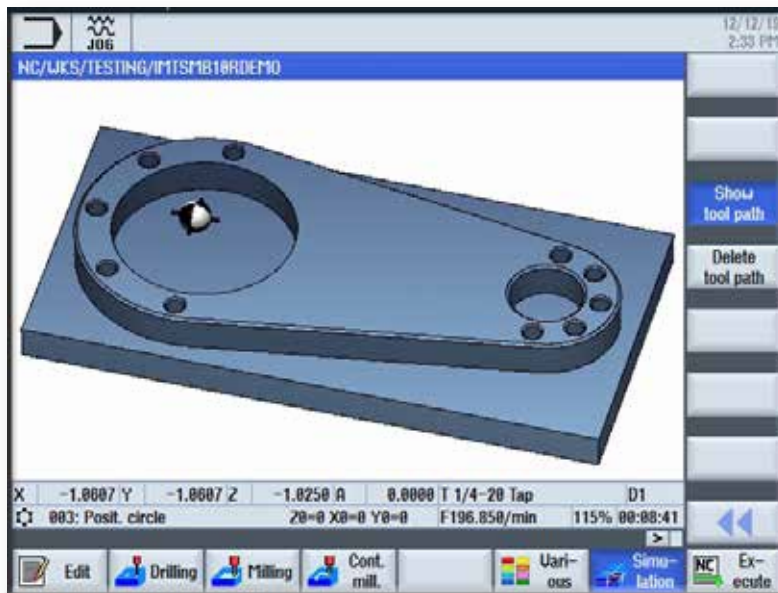
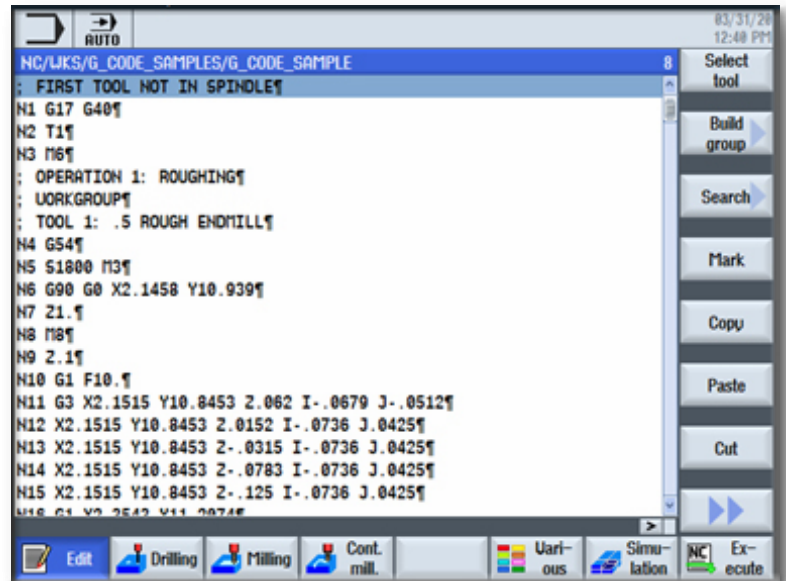

SIMULATION MODE

Before making any chips the full featured simulation mode lets you see the part in 3D to check if everything is correct compared to the print. Part can be rotated, zoomed and cut to see into different areas of the part. Hole in the wrong place? Fix it before you actually machine it. Simulation even shows cycle time.

Setup and Operation



TOOL TABLE

Graphic display shows the type and name of the tool. You can also control spindle direction and coolant. Tool life monitoring is also standard for time in cut or part count.



PART PROBING/ MEASURING CYCLES

Several standard cycles are available to find centers of holes, part edges, and bosses. Cycles can also be used to measure finished parts and display the reading.



HANDWHEEL RUN

This feature allows you to control your program execution with the optional electronic handwheel. Turning the handwheel causes the program to run with you in charge of the axis feed. Turn it slow or speed things up by cranking faster. When you stop turning the axes stop moving, turn the handle the opposite direction and the axes move backwards though the program. Designed to make proving-out programs easier with safety and confidence.

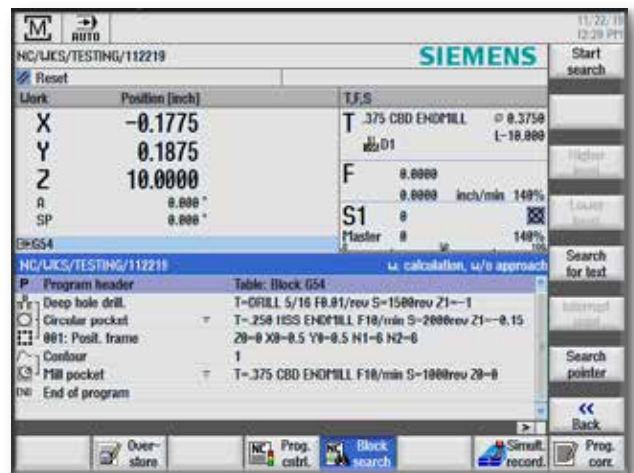

RUN PROGRAM & MID-PROGRAM START

After the program is proved out in simulation you are ready to run. The Auto screen Block Search function lets you start anywhere in the program. Part counters and run times are also included.

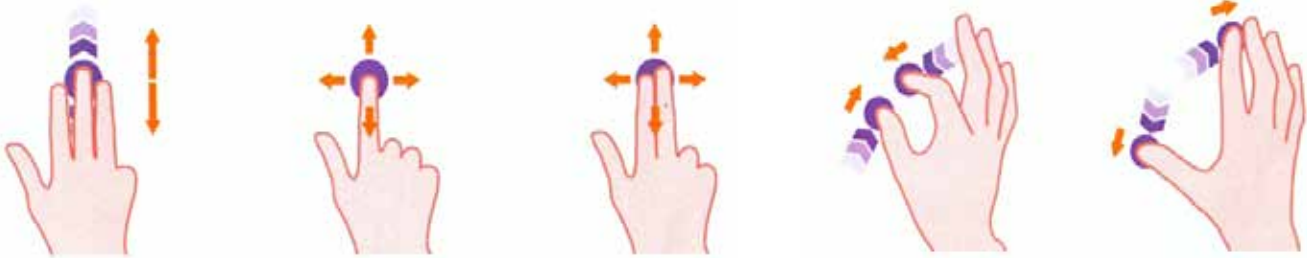

MULTI-TOUCH SMART SCREEN

Smart Operation with Multi-Touch interface will give you many of the same familiar functions as other touch screen devices. Scrolling, pinch and zoom and Soft Key selection are intuitive and easy to use.



TOOL PROBING

Standard animated cycles make tool length and diameter setting fast and easy. Large diameter tools will automatically shift the tool over to touch the probe on the tool high spots.



MULTIPLE CLAMPING

This unique standard feature lets you setup multiple parts on the machine. It re-writes the program to reduce the number of tool changes to produce parts faster. For example when a drill is called up it will drill all the pieces before going to the next tool. Can also be configured to run multiple sides of a part.

Advanced Features

3D HIGH SPEED MACHINING

Features high speed 1.5ms block processing and 500 block look-ahead. Advance Surface features jerk control and nano smoothing with a compressor mode which determines optimal velocity for programs containing circular and linear blocks. High speed roughing parameters and lower speed finishing parameters provide incredible surface finish at lowest possible cutting time.

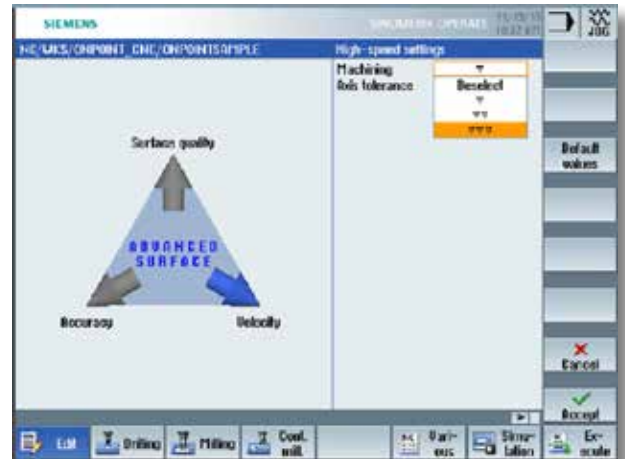

4TH AXIS SURFACE CYCLES

Allows programming of XYZ coordinates and cycles like pockets and engraving. These are then automatically projected onto a cylindrical surface. For use with 4th axis rotary tables.

ADAPTIVE FEED CONTROL

The Adaptive Feed Control cycle monitors the spindle load and varies the feed rate accordingly. By entering the maximum spindle load and then entering a range of minimum and maximum feedrate override values, the control monitors these settings and adjusts the feeds automatically. When approaching corners and radii the feed rate will slow down, during straight line moves the feedrate increases to shorten the cutting time and help produce more parts per hour.

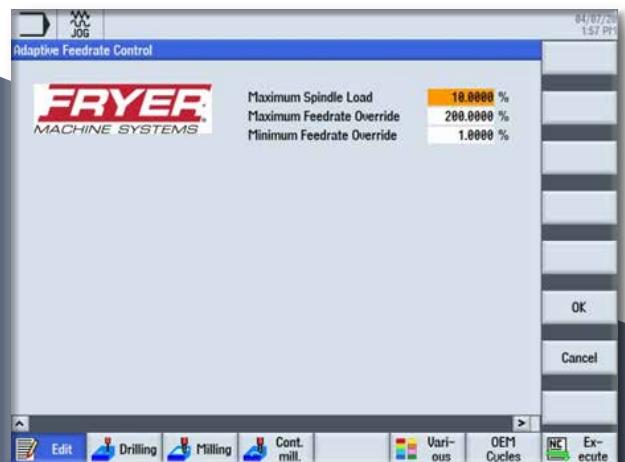

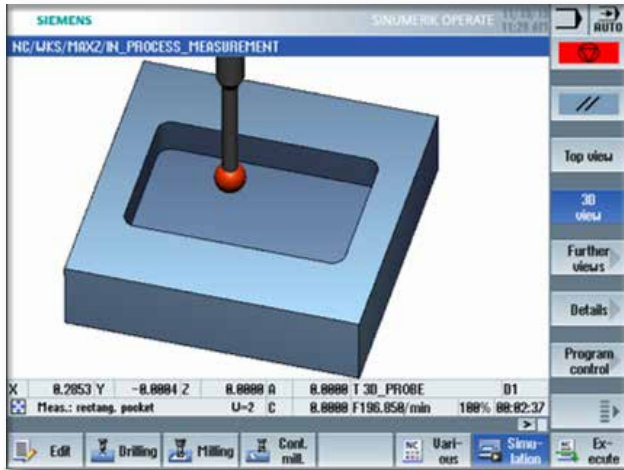

IN-PROCESS PROBE MEASUREMENT CYCLES

This feature allows you to measure part features during program execution. Can also be used in MDI mode after cutting the part to then measure certain features and display the measurement.

COLLISION AVOIDANCE - REAL-TIME, 3D PROTECTION MONITORING PROTECTION YOU CAN USE

Collision Avoidance provides protection by monitoring the static machine tool components in 3D and in real-time. Works in every operating mode including Jog, MDI and Automatic. With Collision Avoidance, the potential for machine components colliding is greatly reduced or even eliminated, making the process more cost-efficient.

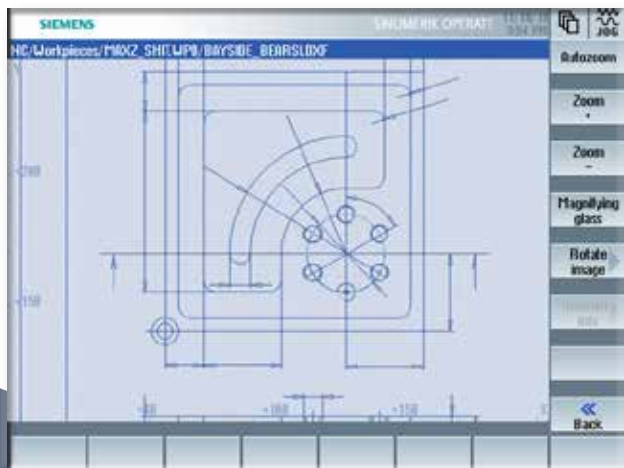

DXF FILE IMPORT FEATURE

Allows you to import DXF files and quickly convert to a conversational program. Automatically create points for drilling operations or contours for milling.

Advanced Features

LIVE TOOLING AND 4TH AXIS

Both mill and lathe versions of the 2300 easily handle live tooling applications. 4th axis rotary tables on mills or live tool turrets on lathes allow programming in simple conversational or posted G code. Surface Transformation software visually lets you define a pocket on a cylinder for example. Tell the control what diameter the blank is and it will automatically wrap the pocket around it. Control graphics will show the part rotating and tools cutting in a 3D simulation.

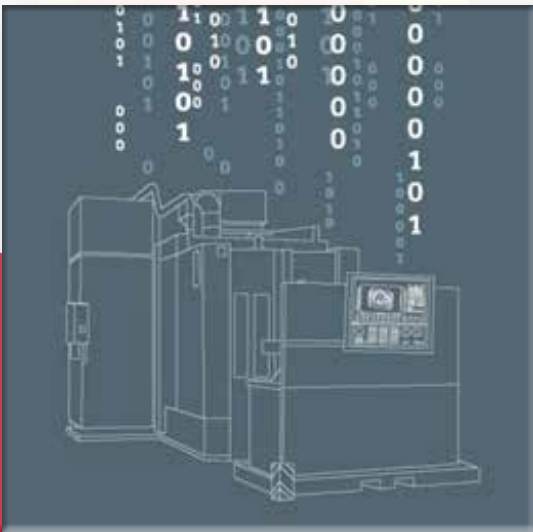
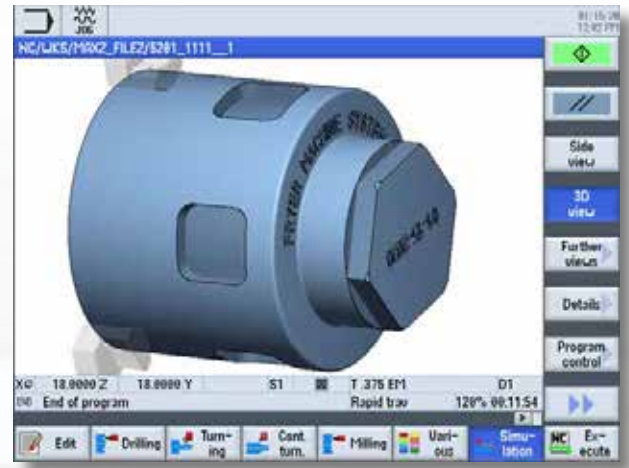

THE CONNECTED SHOP FLOOR

Digitalization can be implemented on every level of machine tool operation. With MindSphere apps like Manage MyMachines and OEE Monitor, you can:

- Increase the productivity, reliability and availability of your machine tools
- Monitor and manage distributed machines
- Ascertain the machine status, operating mode, and program status
- Calculate the overall equipment effectiveness (OEE) to optimize your production efficiencies

SIEMENS OFFLINE PROGRAMMING SOFTWARE

Easy-to-use software package that installs on a standard desktop PC and duplicates the control functions. Allows full programming and part verification. Single package for lathe and mill.



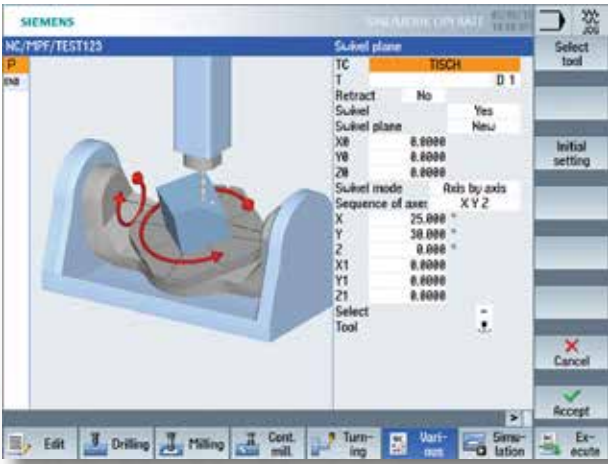

5 AXIS MACHINING

The Fryer Touch 2300 control can be configured to control 5 axes and beyond. Having the power to also program 5 axis conversationally is unique to the 2300. Many advanced features become part of the 5 axis configuration such as:

- Inverse time function
- Spline interpolation for 5 axis
- Tool center point compensation and programming using vector or RPY angles
- 3D tool nose radius compensation

MIXED TECHNOLOGIES

Advanced help cycles with powerful graphical capabilities within the control make multi-tasking easy. A machine using mixed technologies, such as combined milling and turning, can do the work that was previously done by two or more machines. The process of combining milling and turning operations on the same machine tool not only improves part quality, but also reduces your manufacturing time.

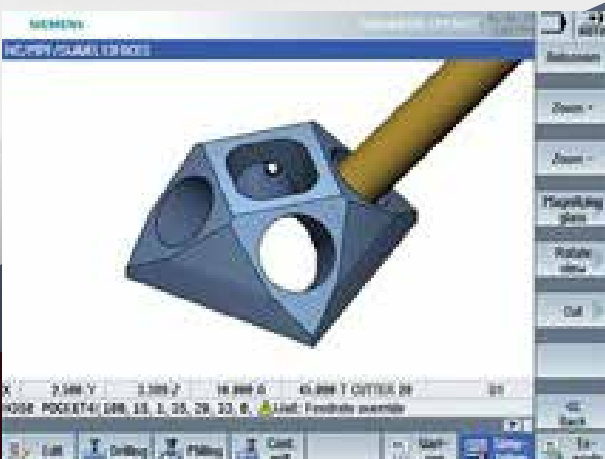
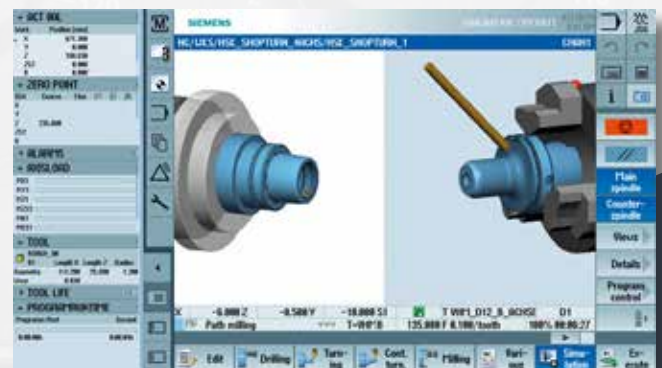

KINEMATIC INDEPENDENCE 3+2 / 5-AXIS SIMULTANEOUS

Today's advanced CNCs optimize program creation by simplifying the mastery of kinematics (the geometry of motion) that goes into the programming of machines. This approach allows the same program to run across multiple 5-axis machines that have different kinematics without the need for a separate post-processor for each machine tool. "TRAORI" — 5-axis tool center point management maintains the optimum tool position dynamically using simple commands.

FRYER / SIEMENS TOUCH 2300 FEATURES AND TECHNICAL DATA

PROGRAMMING MODES

Graphical Conversational Programming:

- Simple fill-in-the-blank menus
- No G-Code knowledge needed
- Graphical help screens ease learning curve
- Simple adding, deleting or modifying of work steps
- Simultaneous verify draws each step as you program
- Multi-lingual menus standard

G-Code Programming:

- Large standard memory for lengthy programs
- Includes search, replace, cut, copy & paste functions
- Translator for Fanuc G-Code
- Merge both conversational & G-Code in the same program

Contour Programming:

- Automatic calculation of partially defined geometry
- Powerful contour calculator for creating contours on the peripheral surface of cylindrical work pieces
- True-to-scale representation of contours with up to 255 contour elements
- Import DXF files via an optional CAD reader

MACHINING CYCLES

Milling:

- Machining of contour pockets with up to 12 islands
- Machining of contour bosses with up to 12 islands
- Automatic detection and follow-up machining of residual material
- Face milling cycle with safe zones
- Rectangular & circular pockets with different insertion methods
- Rectangular & circular bosses
- Linear & circular grooves
- Thread milling and engraving cycle

Turning:

- Single point OD and ID threading
- Pipe and API OD and ID threading
- One button thread repair
- Multiple grooving cycles
- Basic stock removal cycles
- Plunge and face turning
- Live tooling and C axis

Drilling:

- Centering, reaming, boring
- Boring with chip break or pecking function
- Rigid tapping with chip break or pecking function

High-Speed Machining:

- Mold making cycle for the selection of the machining type & contour tolerance

Position Pattern:

- Position patterns such as a line, circle or grid
- Deselection of individual position in position patterns

Cylindrical Surface Machining:

- Drilling & milling operations on cylindrical surfaces
- Features conversational milling & drilling cycles on a live tool lathe

Swivel:

- Drilling & milling synchronized on swivel head machines
- Flexible input of swivel angle makes changing from vertical to horizontal or any angle in-between easy

GRAPHIC VERIFY

- 3D solid model view
- Wire frame graphics view
- Special 3-side view with 3D elevation
- Verify both conversational & G-Code programs
- Run verify draws the part while machining in real time

TOOL MANAGEMENT

- Tool table graphically shows tool type & geometry
- Workpiece count & tool-life monitoring with sister tools
- Tool radius compensations with approach & retract strategies
- 3D tool radius compensation
- Look-ahead detection of contour violations
- Tool management with extensive functionality such as empty location search & place positioning, tool loading/unloading, tool life & workpiece count
- Connection to RFID tool identification system - MOBY E

SET-UP FUNCTIONS

- Graphic menu for setting tool lengths & diameters, milling & turning
- Simple menu for automatic tool setting with optional tool probe
- Menu driven part probe cycles

AUTOMATIC FUNCTIONS

- Block search to an interrupted point in a program
- Block search to a specific point in a drilling pattern with all modal data automatically activated

HIGH-SPEED MACHINING

- Velocity feed-forward reduces following error to near zero
- Jerk limitation for creating smooth ACC/DEC profiles
- Spline interpolation featuring on-line compressor
- Polynomial formatted programs can run directly without conversion to G-Code

5 AXIS MACHINING

- Inverse time function
- Spline interpolation for 5 axis
- Tool center point compensation and programming using vector or RPY angles
- 3D tool nose radius compensation

HARDWARE SPECIFICATIONS

- Siemens 840D SL platform
- 19" color touch screen monitor
- High-speed CPU control up to 31 axes
- Standard memory 3MB expandable to 6GB
- Profibus I/O expandable to 4,096 digital inputs/outputs
- Sinamics S120 modular digital drive system
- Absolute encoders – no homing required
- Regenerative drive system saves 40% electrical consumption
- High-speed Ethernet port -- wired or wireless
- Linux or Windows based platforms